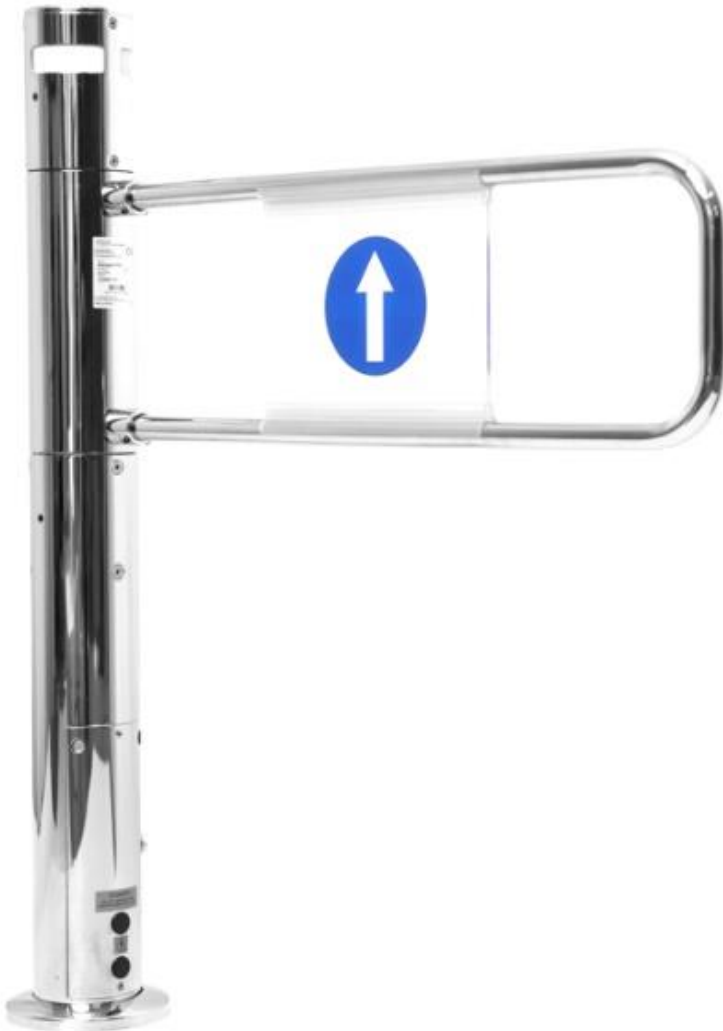


2019

5000 Series Two Way Auto Gate Installation Manual



TURNSTILE SECURITY SYSTEMS

THIS CATALOGUE IS MEANT AS REFERENCE MATERIAL FOR TURNSTILE SECURITY SYSTEMS Inc. FOR THE SOLE PURPOSE OF INFORMING POTENTIAL CUSTOMER OF FEATURE, ADVANTAGES AND BENEFITS OF TURNSTILE SECURITY SYSTEMS PRODUCTS.

11/14/2019

November 14, 2019

5000 SERIES TWO WAY AUTO GATE MANUAL

SERVICE@TURNSTILESECURITY.COM

1-888-371-2222 OR 1-519-833-9494

TURNSTILE
Security Systems Inc.

CONTENTS

1. Contents	2
2. Warranty	4
3 GENERAL INFORMATION	5
3.1 DIMENSIONS.....	5
3.2 DATA.....	6
4 INSTALLATION OF THE AUTOMATIC GATE	7
4.1 CONNECTING THE POWER.....	10
4.2 HIGH CURRENT VOLTAGE!	11
4.3 PANIC ALARM	12
4.4 INSTALLATION OF GATE ARM.....	12
5 TRIGGERING OF THE GATE	13
5.1 INSTALLING THE PEC UPRIGHT AND REFLECTOR UPRIGHT	15
5.2 SETTING THE PEC	17
5.3 SETTING THE RADAR	18
5.4 INSTALLING THE OH SENSOR.....	19
5.5 CHILDSAFE PROTECTION	20
5.5.1 SETTING THE RANGE OF THE CHILDSAFE SENSOR	21
6 MMI – MAN MACHINE INTERFACE	22
6.1 USERINTERFACE – POTENTIOMETERS.....	22
6.2 USER INTERFACE – LED DIODES.....	23
6.3 USERINTERFACE – DIP SWITCHES	24
6.4 NORMAL & SLOW SPEED DIP SWITCH SETTINGS.....	24
(FOR CONTROLLING THE GATE ARM SPEED)	24
6.5 SCO EXIT GATES.....	25
6.6 ALPHAGATE 180° OPENING.....	26
6.7 MAIN BOARD – CONNECTORS.....	27
6.9 ADDITIONAL POWER SUPPLY IN ALPHAGATE MKII.....	28
6.10 CONNECTORS – INDIVIDUAL SOCKETS	29
7 GATECOM	30
7.1 WIRING - GateCOM	30
7.2 UNAUTHORIZED CONFIGURATIONS.....	32
7.2.1 GATECOM – MASTER & SLAVE FUNCTION	33
7.3 GATECOM – ORIENTATION	34

8	HOW TO CONNECT THE SENSORS?	35
8.1	PEC UPRIGHT TO OPEN FIRST LINE OF GATES.....	35
8.2	PEC IN GATE TO OPEN SECOND LINE OF GATES.....	35
8.3	RADAR IN THE TOP OF THE GATE.....	36
8.4	OVERHEAD SENSOR	36
8.5	OPEN PUSH BUTTON	37
9	WHAT IS SECURE, WELCOME AND CLEANING MODE?	37
9.1	HOW TO CONNECT THE "CLEANING" / "WELCOME" BUTTON	38
9.1.1	WELCOME AS A FIXED FUNCTION OF THE ENTRANCE SYSTEM 38	
9.1.2	REMOTE ON AND OFF FUNCTION OF WELCOME MODE	39
9.2	CONNECTING EXTERNAL TRIGGERING (ACCESS CONTROLS).....	39
10	WIRING OF LED CABLES IN ALPHAGATE MKII	40
11	230V AC or 110V AC GATE?	41
12	FAQ	42
12.1	HOW TO TEST THE GATE?	42
12.2	HOW TO TURN OFF THE ALARM?	42
12.3	HOW TO TURN OFF THE GATE?	42
12.4	HOW TO CUT POWER SUPPLY TO THE GATE?	42
12.5	WHEN DO I USE NORMAL and SLOW?	42
12.6	WHAT IS A GATE FAMILY?	43
12.7	WHAT IS WELCOME MODE?	43
12.8	HOW TO TRIGGER THE ALARM (OUTPUT).....	43
12.9	HOW TO CHANGE SIDE OF THE GATE	43
13	TROUBLESHOOTING THE GATECOM	44
14	ACCESSORIES	45
15	FAILSAFE OPERATION	45
16	MAINTENANCE INSTRUCTIONS	46
17	CLEANING INSTRUCTIONS	46

WARRANTY

All Turnstile Security Systems products are warranted against defects in material and workmanship for a period of 18 months from the date of shipping. We will repair or replace at our discretion any defective product provided it is returned undamaged to our factory.

Freight to be paid at **CUSTOMER'S EXPENSE**, please contact our Service Department, before returning the product.

Beyond warranty period, we will offer replacement parts or Factory Service at reasonable rates.

service@turnstilesecurity.com

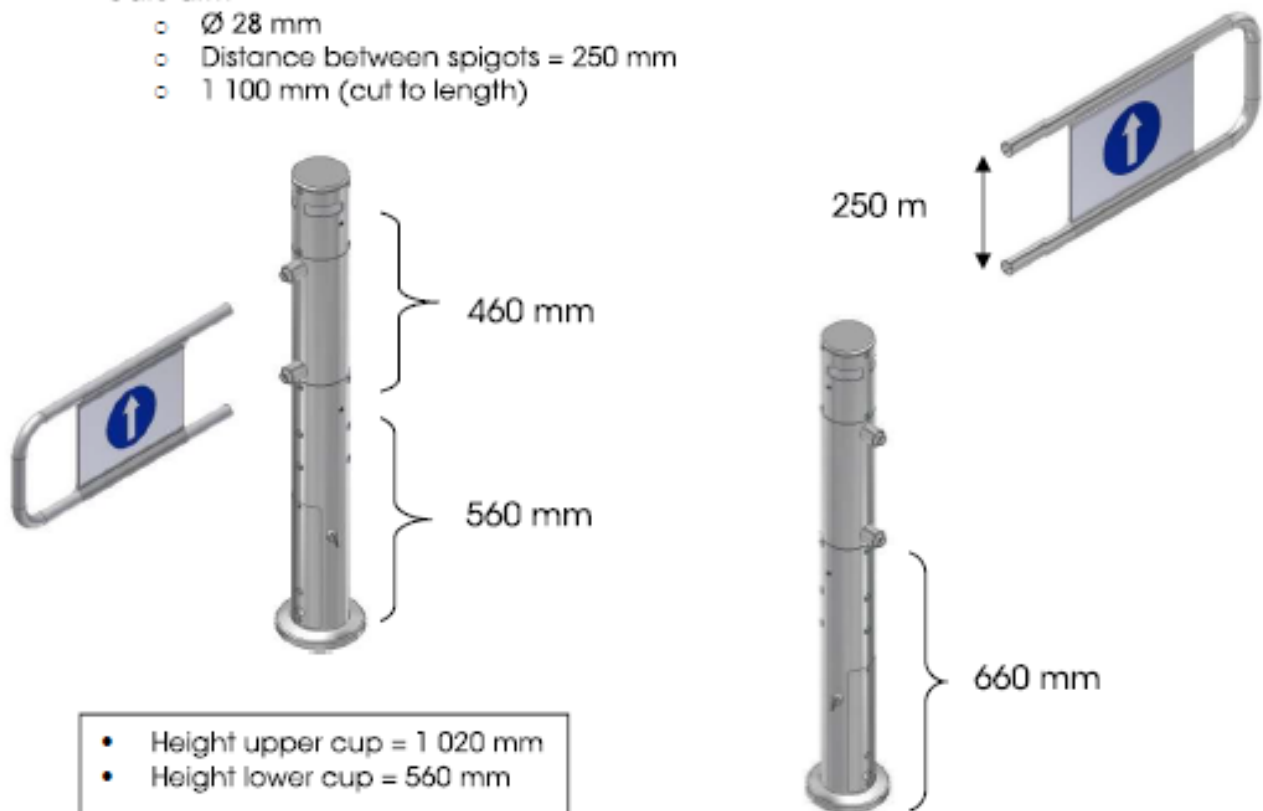
Or call Toll free

1-888-371-2222

3 GENERAL INFORMATION

3.1 DIMENSIONS

- Motorised Column
 - \varnothing 120 mm
 - \varnothing 180 mm inkl. folkåpa
- Height 1 120 mm
- Gate arm
 - \varnothing 28 mm
 - Distance between spigots = 250 mm
 - 1 100 mm (cut to length)



3.2 DATA

DATA

Voltage	230 V AC or selected 110V AC
Frequency	50 Hz
Power	35 W
Temperature	0 - 35°C
IP-classification	IP20
Installation	The Automatic gate is <u>only</u> made for indoor use
Weight	27 kg

MOTOR

Voltage	24 V/DC
Power Rating	20 W
Rated Current	0.9 A

PEC (Photo Electric Cell)

Voltage	10-30 V/DC
Output	NPN
Switching Capacity	100 mA
Power Input	25 mA

RADAR MOVEMENT DETECTOR

Voltage	12-24 V/DC
Max Power	60 mA
Transmission Frequency	24,175 GHz
Transmission Power	< 5 mW/cm ²
Output	NPN

ULTRASOUND SENSOR – OPTIONAL

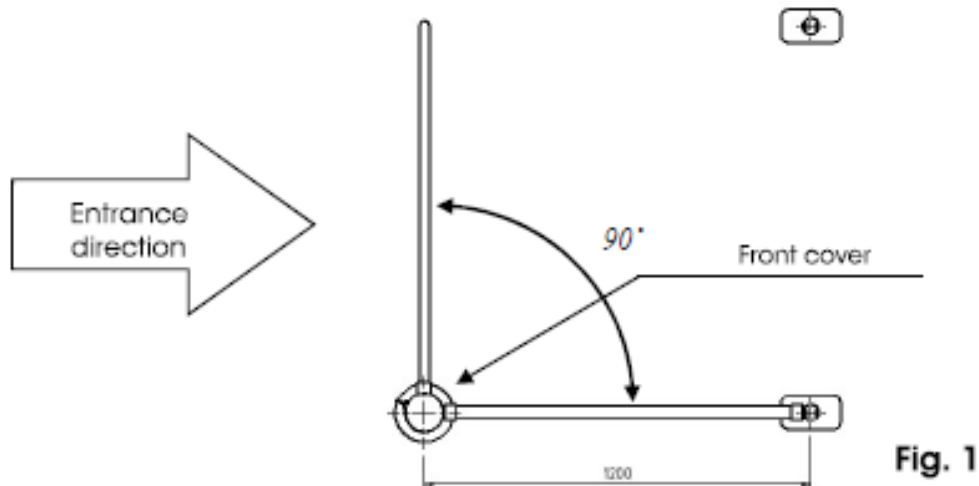
Voltage	15-28V/ DC
Power Input	< 100 mA
Output Signal	Sourcing Output 10 mA
Frequency	40 kHz (pulsing)
Minimum Distance	1 cm
Angle of Cover	-90°
Temperature Range	0 - 70°C

ADDITIONAL POWER SUPPLY – OPTIONAL (SCANMASTER)

AC Current – Input	230 V AC
DC Voltage – Output	12 V
Rated Power	15.6 W
Current Range	0-1.3 A

4 INSTALLATION OF THE AUTOMATIC GATE

The automatic gate is shipped from the factory as a sealed unit ready for installation in the intended location. The gate arm must be at a 90° angle to the direction of entry (See Fig. 1).



- Mark the drilling points using the mounting plate of the automatic gate. (See Fig. 2)
- The entrance system must be affixed using suitable fixings, making sure that the automatic gate is secured to the floor.
- The floor fixings for the entire entrance system should be specified to suit the floor material and construction (Shielded anchor, chemical fixings etc.) to ensure stability and safety to the entrance system.
- Make sure to pass all the cables through the base plate before fixing the gate to the floor.
- Ensure that electronic parts and cables are not damaged when drilling holes for rail cups in the Alphagate. Metal shavings can damage the electronics!



Ensure that electronic parts and cables are not damaged when drilling holes for rail cups in the Alphagate. Metal shavings can damage the electronics!

If the gate arm needs to be adjusted, loosen the screw that holds the coulisse and move the coulisse a little bit to the left or to the right depending on how the gate arm needs to be adjusted. Move carefully, small movements is enough to adjust the gate arm several centimetres. When the gate arm is satisfactory adjusted, fasten the screw again. To be able to do this adjustment, the power needs to be switched on to the gate. Make sure no sensors are connected during this setup, it may break the coulisse!

Move to the right → gate arm moves to the left

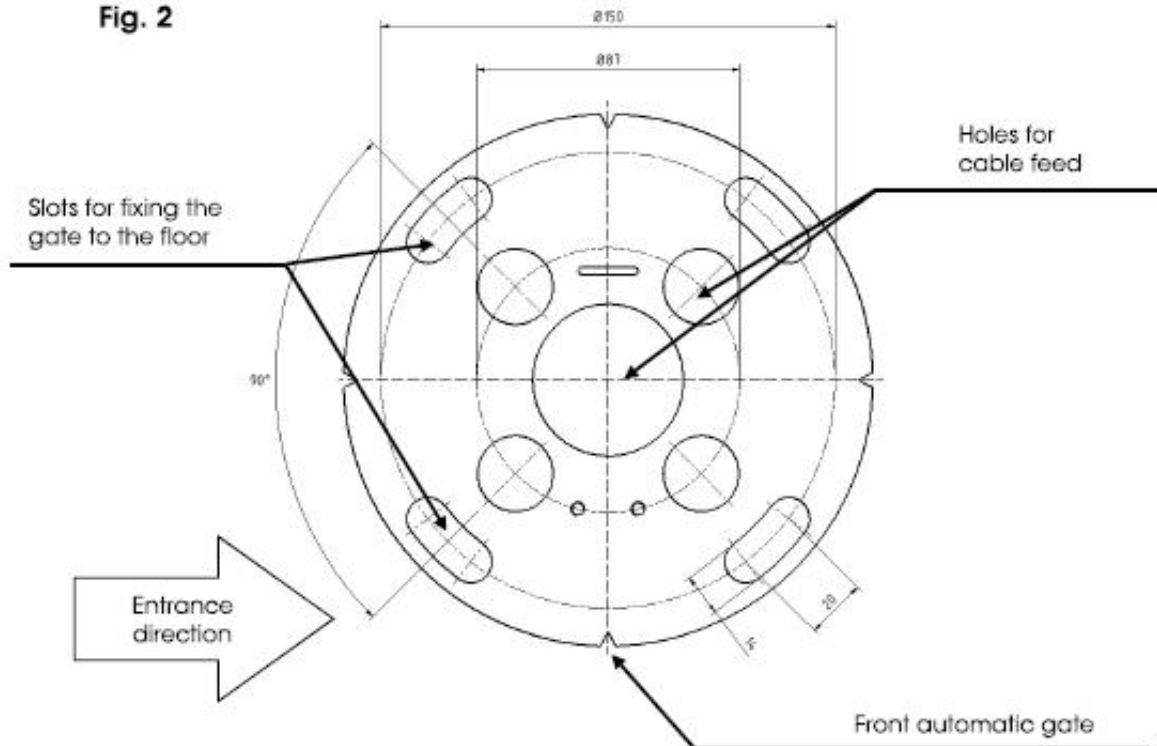
Move to the left → gate arm moves to the right



Make sure no sensors are connected during this setup.

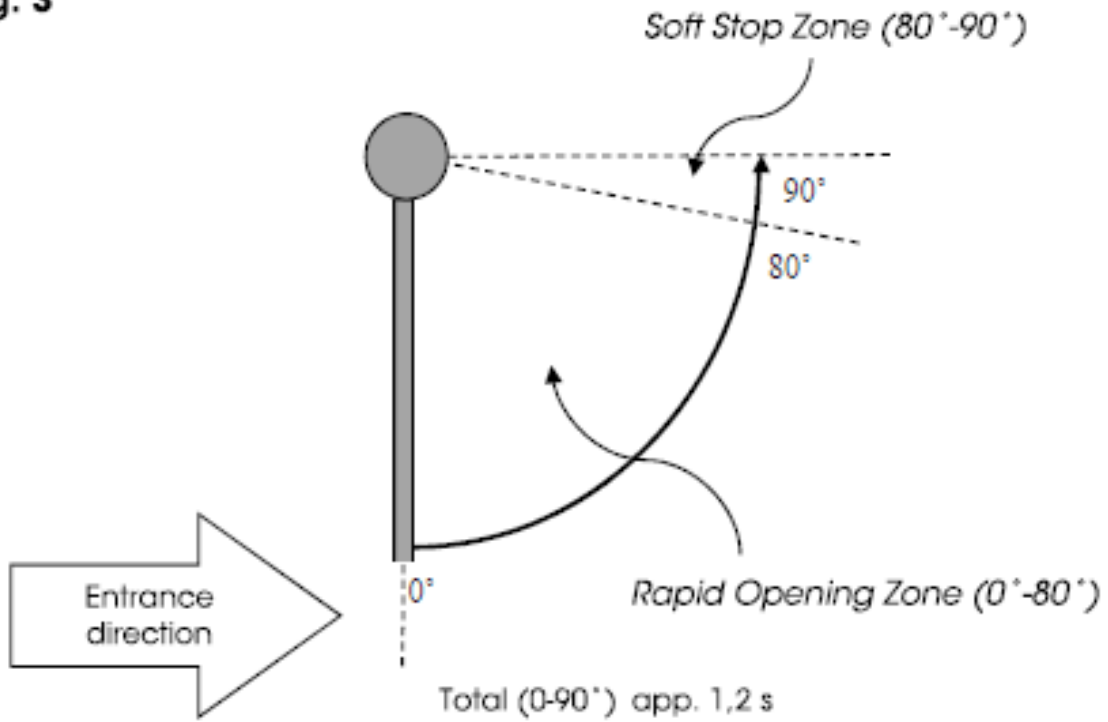


Fig. 2



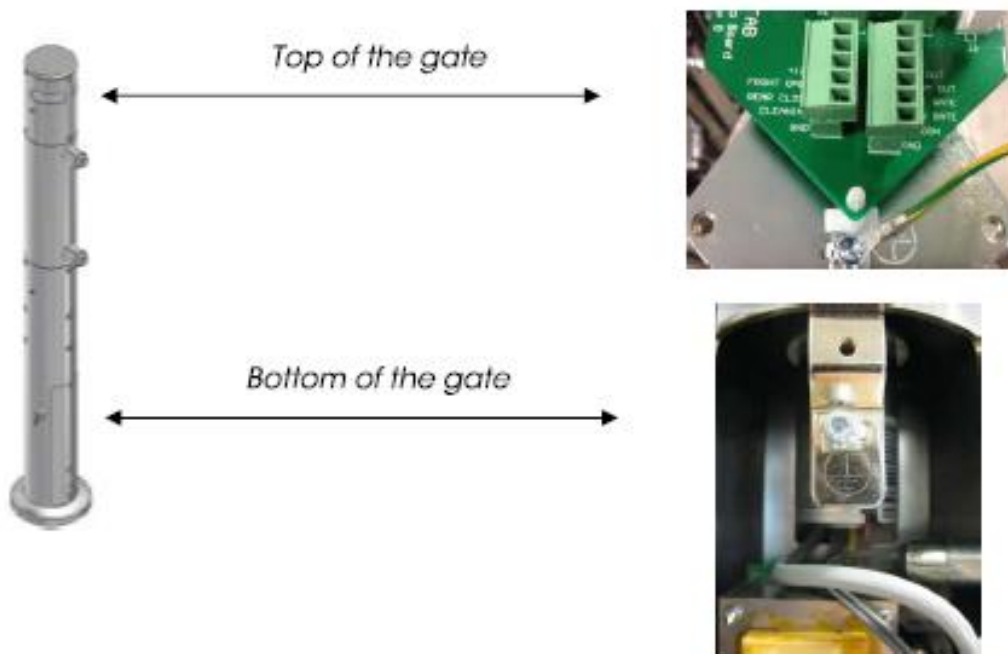
Before fixing the gate permanently to the floor the gate must be powered up to ensure a correct 0 degree initial position. Note: Make sure the approach delay is not set to minimum when testing the gate to enable gate to fully open 90°.

Fig. 3



4.1 CONNECTING THE POWER

Note: The chassis of the automatic gate must be grounded at specifically marked connection points.



4.2 HIGH CURRENT VOLTAGE!

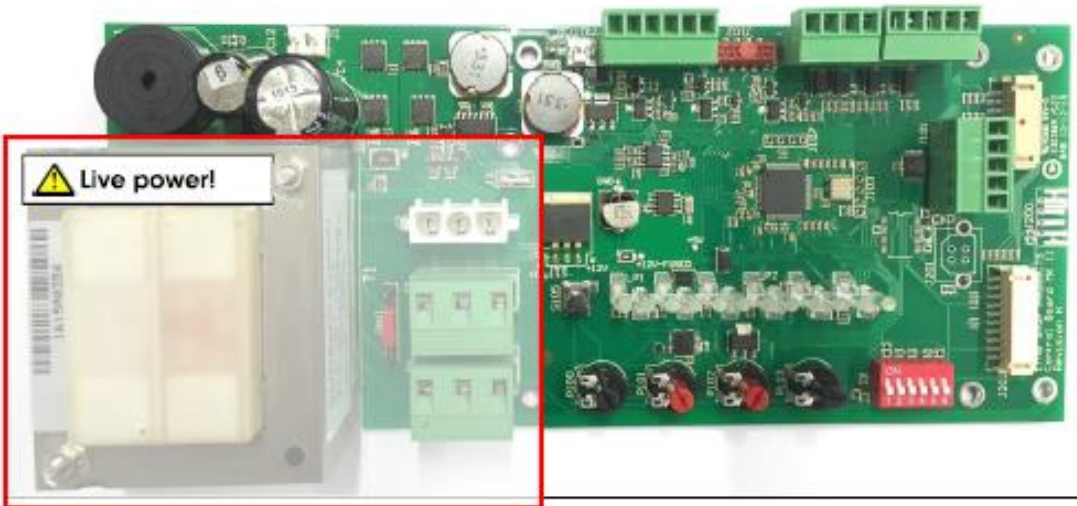


The main power terminal is dangerous when the automatic gate is powered up. Always disconnect the power to the mains terminal before conducting any work to the gate.

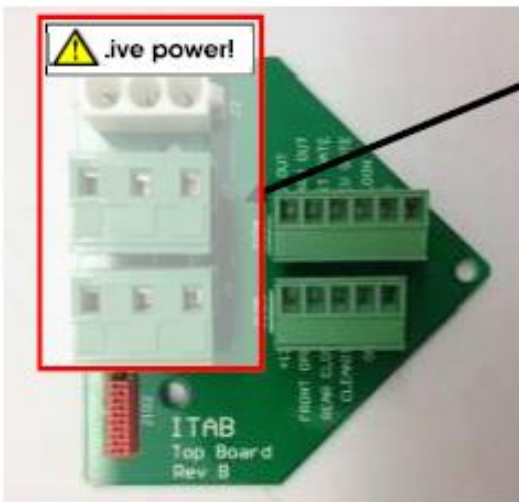


The power feed to the system must have a max. 10A fuse.
Maximum cable area for incoming mains terminal = 2.5 mm²

Area of live power feed - Main board



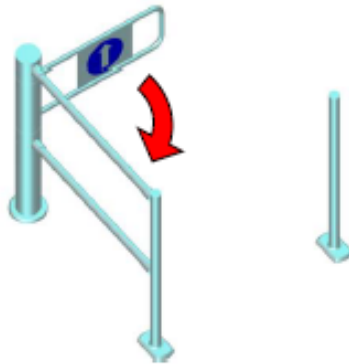
Area of live power feed - Top board



Incoming mains terminals are located in bottom and the top of

4.3 PANIC ALARM

When exiting/entering through the automatic gate, moving the gate arm manually without the gate being triggered to open, an alarm will sound and the anti-panic resistance will be activated. The electronic entrance system equipped as standard with a device that triggers an acoustic warning when the system is forced to be opened manually. After being triggered into panic mode the gate arm will reset itself **automatically** to 0° position and the alarm will be turned off. The gate is then operational again.



- Emergency exit = panic brake out in the opposite direction of the entrance direction
- Alarm sound
- **Automatic** reset of gate arm

4.4 INSTALLATION OF GATE ARM

(1) Cut gate arm to the desired length using a saw or pipe cutter.



(2) Attach sign holders to sign.



(3) Insert sign into gate arm.



(4) Fit gate arm on to spigots and secure the gate arm with the two grub nuts. Tighten with 24 Nm.

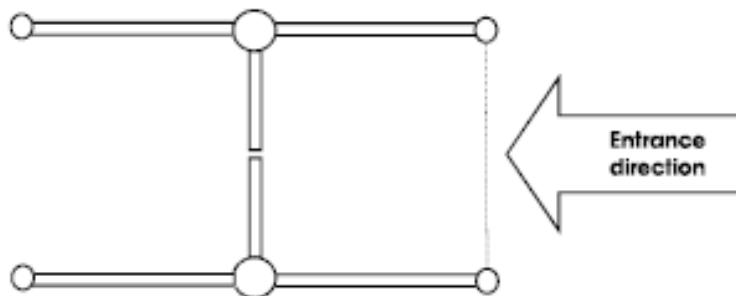


5 TRIGGERING OF THE GATE

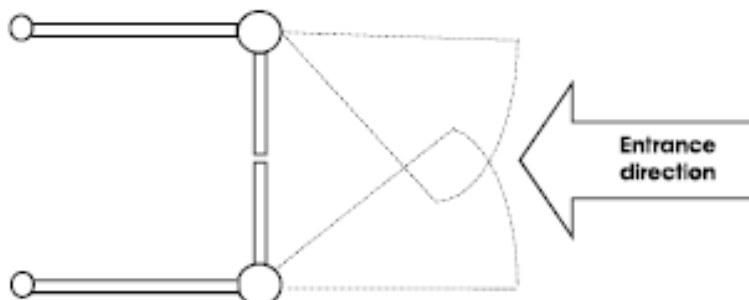
The automatic gate can be opened by variety of different triggers. The simplest being a normal switch/push button or a remote control. The most common triggers are PEC and radar, with the overhead sensor as an option for special installations.

- PUSH BUTTON
- REMOTE CONTROL
- RADAR
- PEC
- SCANNER
- OVERHEAD SENSOR

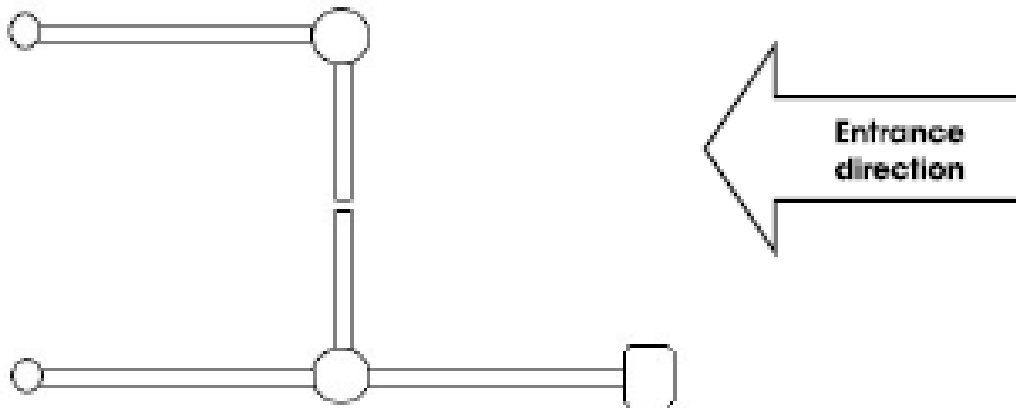
Overview of the PEC



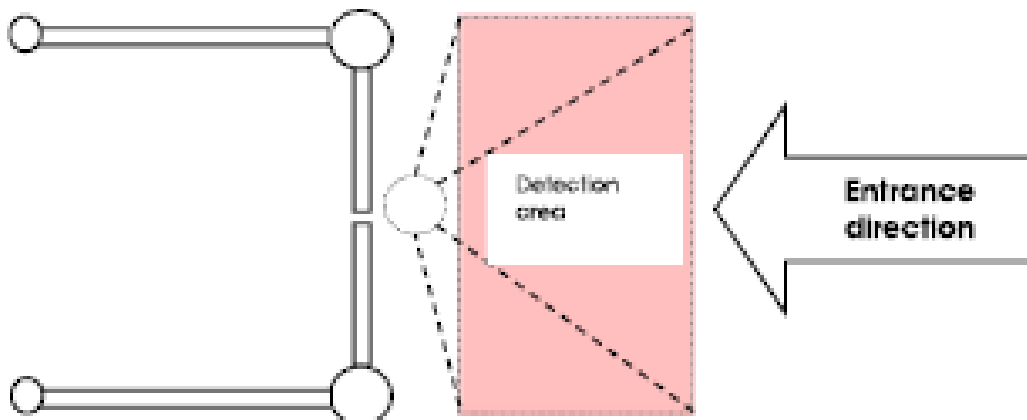
Overview of the RADAR



Overview of the SCANNER (Exit Flow)



Overview of the OVERHEAD SENSOR



5.1 INSTALLING THE PEC UPRIGHT AND REFLECTOR UPRIGHT

PEC upright

Position the PEC upright at a distance of minimum 1 200 mm from the automatic gate. The angle between the gate arm on the automatic gate and the cross tube must be 90°, this value must be checked before drilling the holes for the upright. (See Fig. 4) After affixing the system the angle can be corrected within the range of max. 3-4°.

Reflector upright

After installation of the PEC upright, the Reflector upright must be installed in line with the PEC upright, i.e. the reflector of the Reflector upright must be able to reflect the light beam of the PEC sensor in the PEC upright. (See Fig. 4)

- Recommended distance between PEC upright and reflector upright.
 - Single unit maximum 1 150 mm
 - Saloon unit maximum 2 300 mm

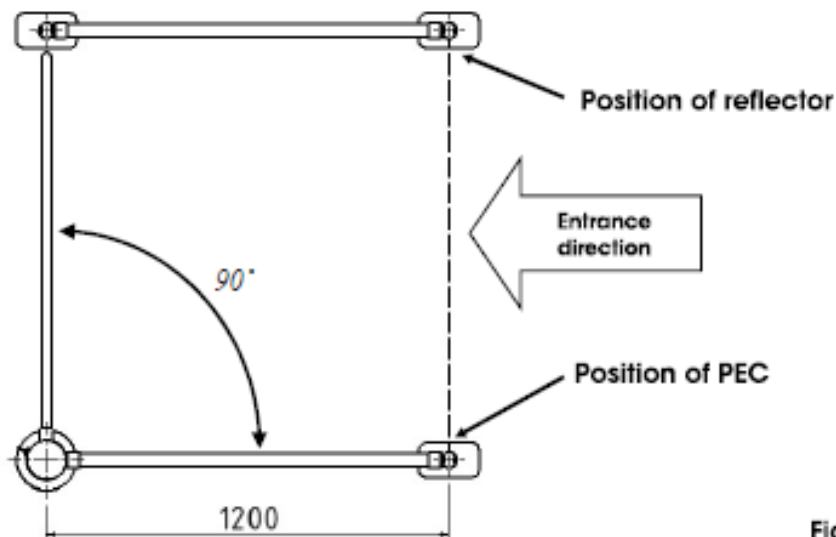


Fig. 4

Installing the PEC upright and the reflector upright

- Mark the position of the drill holes using the mounting plate (fig. 5).

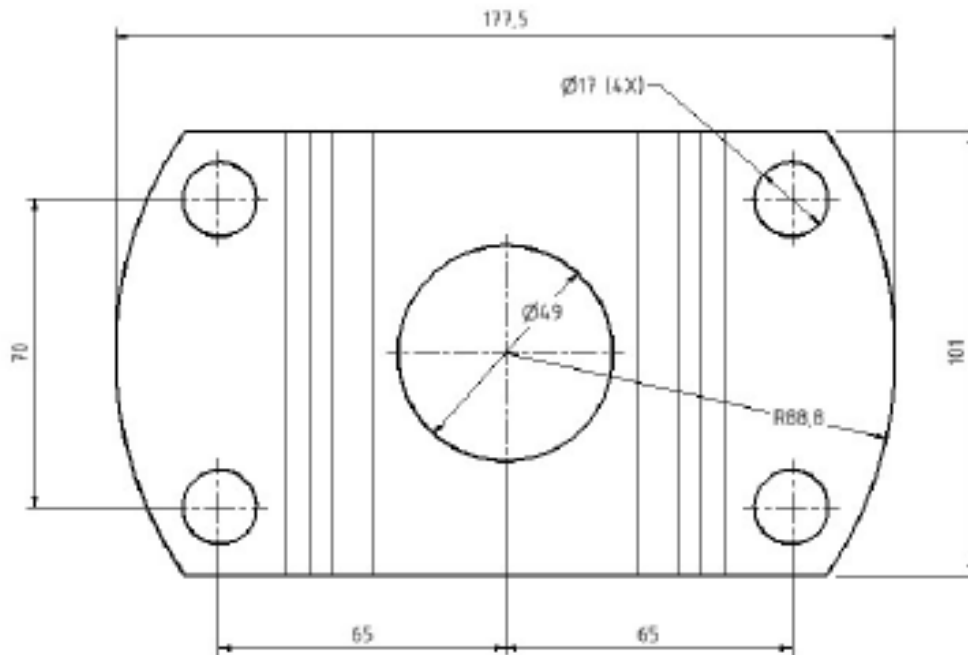


Fig. 5

5.2 SETTING THE PEC

In a PEC system, the gate opens when an object breaks the beam of light, and closes automatically after a set period, once the beam is cleared.

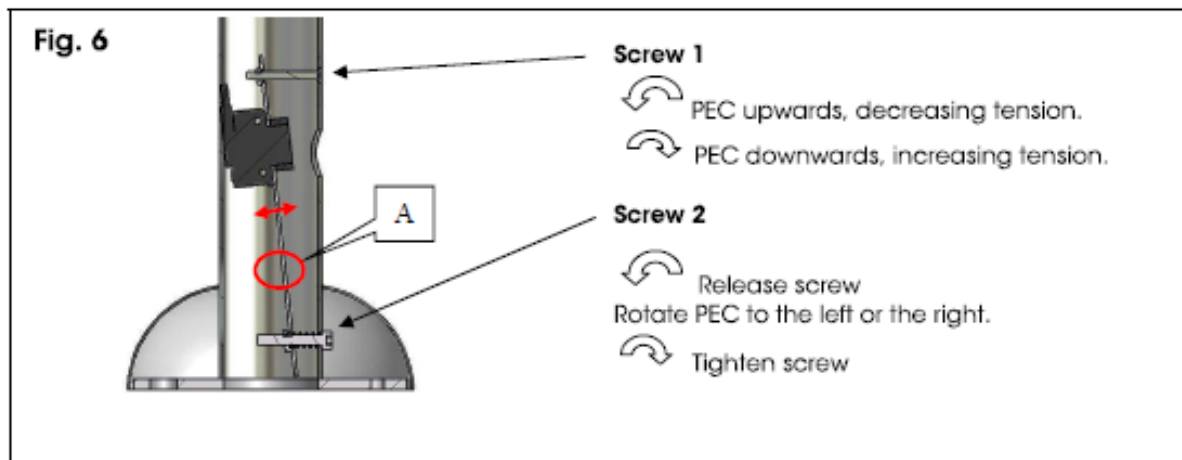
When setting the PEC the open time delay should be set to "min" at the potentiometer no. 1 at the control board.

The bracket of the PEC sensor is spring loaded (see red arrow). The upper screw 1 is for adjustment vertically.

When the lower screw 2 is tightened firmly, the bracket sits against the inside of the upright tube (see red circular). Due to the shape of the PEC bracket being in the shape of a hexagon a pivotal point is created (red circle A) allowing the top screw to adjust the PEC vertically. To adjust the PEC sensor horizontally, the upper screw 1 needs to be released (rotate screw to the left) and then the lower screw 2 is to be released (rotate screw to the left) to be able to move the PEC bracket to either the left or the right. Then retighten screw 2 and adjust the vertical angle with screw 1.

Rotate Screw 1 (Fig. 6) to adjust the horizontal angle of the photoelectric barrier. For horizontal adjustment Screw 2 must also be released.

Release Screw 2 (Fig. 6) to adjust the photoelectric barrier to the left/right, and retighten screw after adjustment.



NOTE: After setting up the PEC the opening time must be reset to the desired time.

Adjusting the PEC

- Connect the PEC to power it up. Now the GREEN led light should be on.
- Trim the vertical and horizontal angle of the PEC until the YELLOW led light is on. NOTE: the yellow led must show a steady light, flickering light is not optimal.



5.3 SETTING THE RADAR

This section is for a gate ordered with radar. The system opens when an object reaches and approaches the area of coverage and closes automatically after the set open time.

Fig. 7 Area coverage
"low sensitivity"

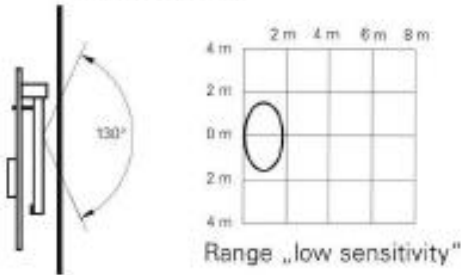
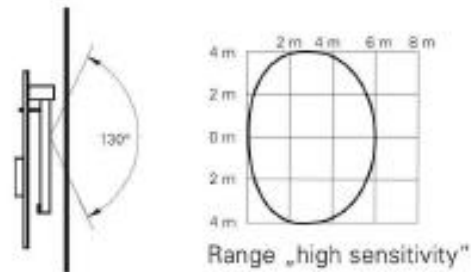
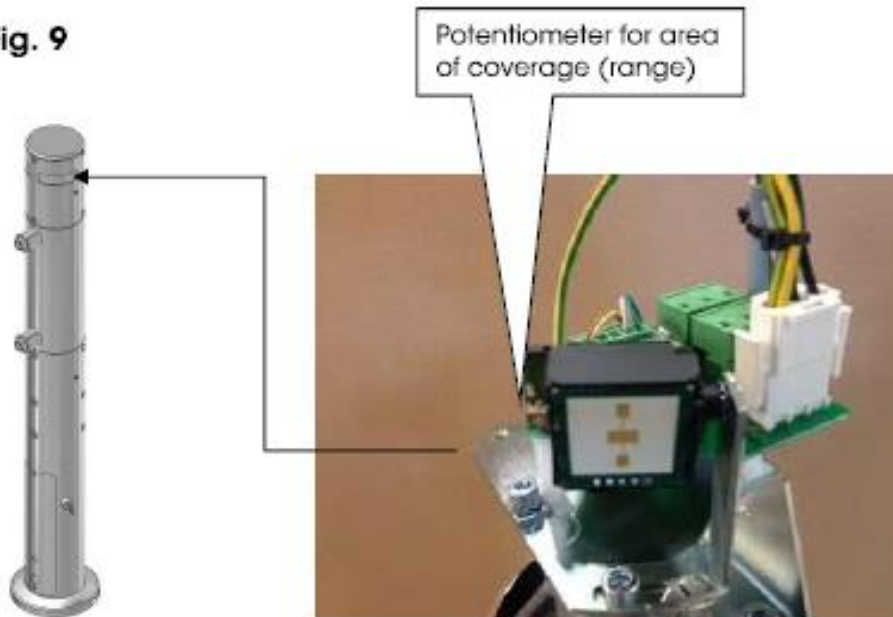


Fig. 8 Area coverage
from above



Adjust the area by turning the potentiometer on the radar front. Test the setting after the top is installed.

Fig. 9

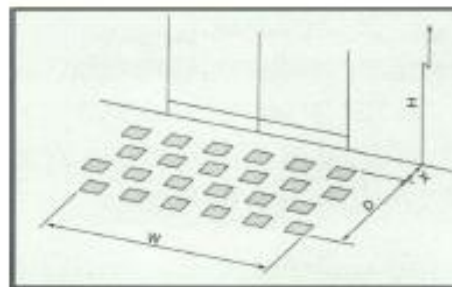
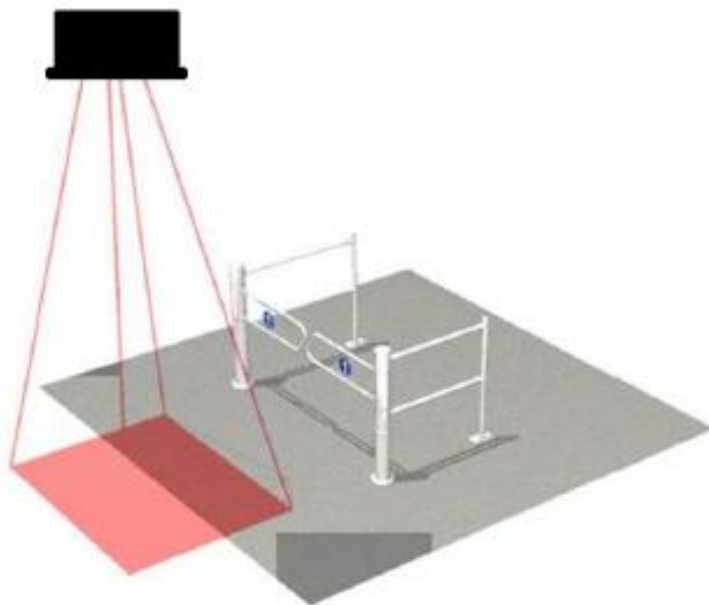


NOTE: After setting up the radar the open time must be reset to the desired time.

5.4 INSTALLING THE OH SENSOR

The Over Head (OH) sensor is to be installed at the height between 2-4 m. If several OH sensors are installed in the same area, they need to have different settings on the dip switch panel to avoid interference between them.

The OH sensor is normally installed to trigger two gates in a saloon configuration. In order to achieve this, the gates must be connected through the GateCOM. The connection can be made in one gate and the saloon gate will receive the signal via the GateCOM.

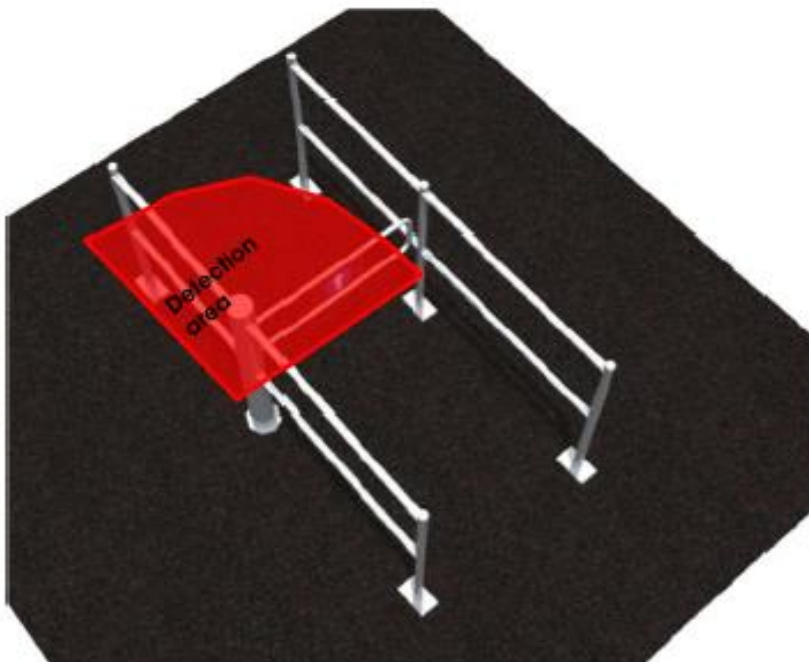


The Over Head sensor enables the user to have a very specific trigger zone (footprint) set in front of the gates.

5.5 CHILDSAFE PROTECTION

Chidsafe is an Ultrasonic Sensor that is used as a safety device to protect children from being injured by the moving gate arm. The Ultrasonic sensor is a presence sensor designed to detect the presence of a person in the area behind the gate where the gate arm operates.

Therefore it is very important that there are not any obstacles within the detection area, for example it is important that the uprights are installed at the right length from the gate so the sensor does not detect them. Also the area is slightly bigger, so obstacles outside the rails could be detected. Do not place baskets or shopping carts close to the chidsafe sensor detection area.



5.5.1 SETTING THE RANGE OF THE CHILDSAFE SENSOR

The covered area should be at least the same length as the gate arm. But it is recommended to set as big detection area as possible, due to reaction time if a person walks into the area. The bigger detection area, the safer operation.

To adjust the range for the detection area, turn the potentiometer clockwise to increase the detection area according to the chart below.

Wiring:

Red = + 12 V

Black = GND






Blue = Childsafe (signal)



Setting	Range (cm)
0	75
1	80
2	85
3	90
4	95
5	100
6	105
7	110
8	115
9	120
A	125
B	130
C	135
D	140
E	145
F	150

6 MMI – MAN MACHINE INTERFACE

6.1 USERINTERFACE – POTENTIOMETERS

Potentiometer	Colour	Function	Time	Description
 DELAY/SCO	Black	NORMAL OPENING	0 to 10 s	DELAY: Adjusts the time opening delay when gate has being triggered to open.
		SCO FUNCTION CLOSE	0 to 8 s	SCO: Adjusts the time until the gate closes after receiving a closing signal from the PEC (local photocell).
 CHILDSF	Red	CHILDSAFE	0 to 10 s	Adjusts the delay time to cut the power to the motor after receiving a signal from the chilsafe sensor. This enables customers to walk through the chilsafe sensors coverage area without triggering the chilsafe.
 SECURE/SCO	Red	NORMAL SECURE	2 to 10 s	Adjusts the delay time of the gate to be operational after the SECURE sensor has stopped triggering.
		SCO-gate: ULTIMATE TIME-OUT	0 to 32 s	SCO: Adjusts the ultimate time out for the gate to close if no signal has been received from the local photocell (PEC) to close.
 PANIC FORCE	Black	PANIC FORCE	40-60 Nm	Adjusts the brake out force. *  (see below)

Potentiometers

If turned anti clock wise = decrease, min-value
 If turned clock wise = increase, max-value



* NOTE: The brake out force is dependent of the length of the gate arm.

6.2 USER INTERFACE - LED DIODES

LED diodes general:

- > **Steady light** = Everything OK.
- > **Blinking light** = Malfunction. There is a fault in the system (it is normal for the light to blink every time the function of the light is triggered).
- > **No light** = Function disabled.

LED light+ Test button	Colour	Function	Description
	Black button	TEST	Push the button to test the gate when powered up.
	Blue	OPERATE	Indicates power to the gate with the motor enabled. When the diode flashes the key switch is OFF or out of function.
	LED	LED	2 s signal in SCO mode for scanner LED diode.
	Green	MOTOR	Indicates power to the motor to open/close.
	Green	WELCOME	Indicates Welcome mode.
	Red	ALARM	Indicates alarm.
	Green	NEXT GATE	Indicates communication to the Next Gate.
	Green	PREVIOUS GATE	Indicates communication to the Previous Gate.
	Green	SALOON GATE	Indicates communication to the Saloon Gate.
	Green	FRONT OPEN	Indicates received opening signal.
	Green	REAR CLOSE	Indicates received closing signal.
	Green	OPEN NEXT/SCO CLOSE	Indicates received closing signal for the Next Gate or closing signal for SCO gate.
	Green	CLEANING	Indicates cleaning mode of the gate.
	Red	CHILDSAFE	Indicates received signal from CHILDSAFE sensor.

6.3 USERINTERFACE – DIP SWITCHES

Table below shows different functions to be set by dip switches.

Table 1

DIP SWITCH	Nr	Function	Switch OFF	Switch ON
	1	Alarm	OFF	ON
	2	Direction	LEFT	RIGHT
	3	Alarm time (5 s/10 s)	5 sec	10 sec
	4	Gate set up	NORMAL	SCO*
	5	180° opening	OFF	ON / SCO*
	6	Speed of gate arm	NORMAL	SLOW

* To achieve SCO mode, dip switch 4 AND 5 must be set to ON (right position).

6.4 NORMAL & SLOW SPEED DIP SWITCH SETTINGS

(FOR CONTROLLING THE GATE ARM SPEED)

The kinetic energy of an object (in this case a gate arm) is dependent upon the weight and the speed of the object. To reduce the kinetic energy of the Alphagate MKII the DIP switch no. 6 can be set to SLOW.

As the safety of an automatic gate is of great concern, the dip switch settings must be complied with to ensure continued safety.

Recommended settings for dip switch no. 6:

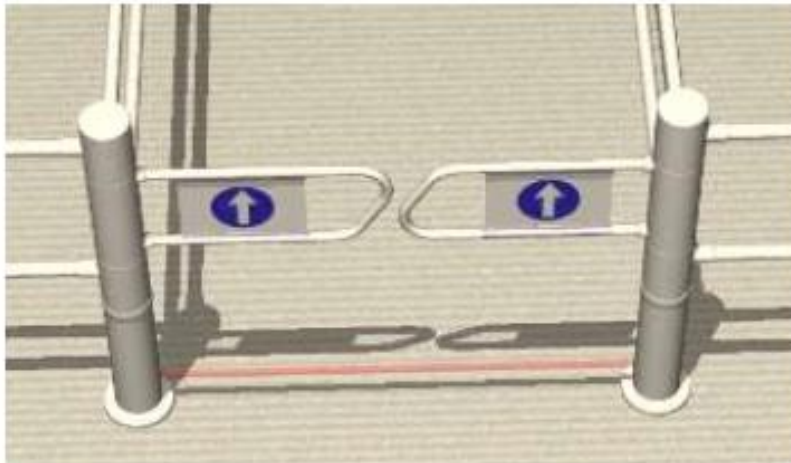
NORMAL - Standard gate arms shorter than 900 mm and gate arms with a weight less than 3,5 kg.

SLOW - Deep gate arms, long standard gate arms (> 900 mm) or gate arms heavier than 3,5 kg.

6.5 SCO EXIT GATES

- Follow the general installation instructions as described in chapter 4 Installation of the automatic gate in the entrance system.
- We recommend installing the exit gates at no wider distance than 1400 mm in order to ensure the maximum security of the exit area.
- All *Alphagate MKII* have the SCO-mode/Exit mode. Just move dip switches 4 and 5 at the main board to the right hand side in order to set the gate in SCO mode.

Note: In order to have the function of an SCO gate, it needs to have a PEC installed in the gate.



- The function of the PEC in the gate when it is in SCO mode is to start the approach delay timer. This is to close the gate after a person has exited through the gate(s). (Approach delay is set by the first potentiometer from the top). If a second person exit during closing, the gate arm will stop for 2 seconds (to prevent children from being hit by the gate arm), then close slowly to its 0-position.

Function description:

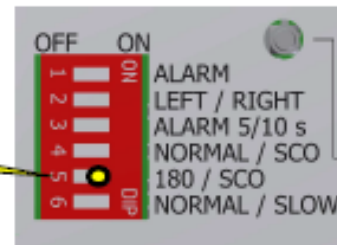
1. The receipt is scanned and the system sends an opening signal to the gate to open.
2. When a person exits and breaks the beam of light of the PEC, the approach delay timer will start to count down in order to close the gates (adjustable between 0 and 8 seconds).
3. The approach delay timer will retrigger if another person exits while the gate is still opened.
4. If the gate has started to close, a new trigger signal is needed to open the gate.
5. The gate has an "ultimate time-out" to prevent the gate to remain open if no one exits through the gates. (Adjustable between 0-32 seconds).

AutoGate 180 Degree Opening

When using the bi-directional function the "Closing input" becomes the opening trigger to open the other hand. Normally this operation is triggered by two switches, one to open left hand and one to open right hand.

Settings:

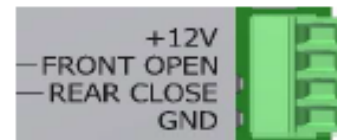
Dip switch no. 5 is to be switched on.



Connections:

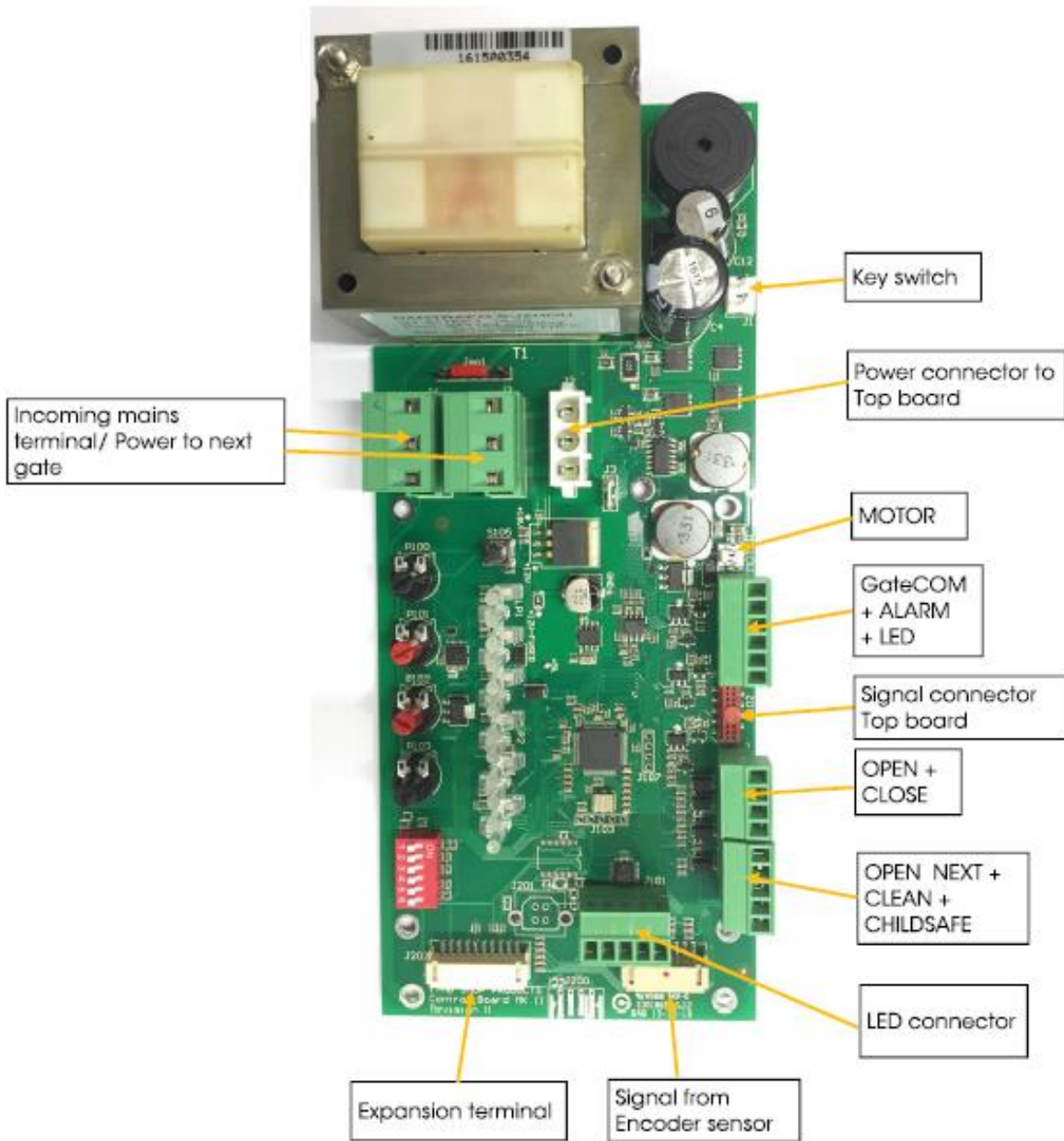
The 1st switch/push button to open in one direction is connected with 2 wires to "FRONT Open" and "GND".

The 2nd switch/push button to open in the opposite direction is connected with 2 wires to "REAR CLOSE" and "GND".

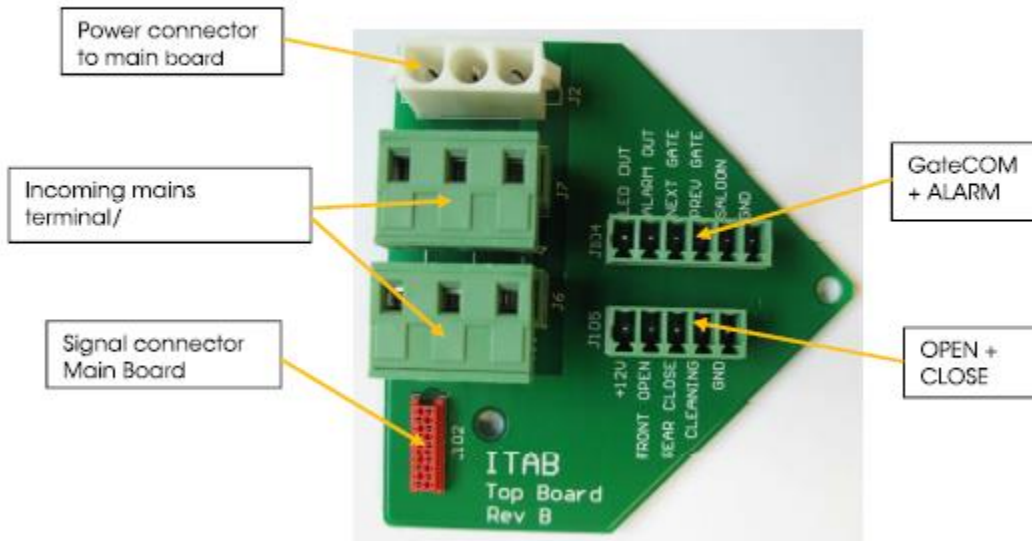


Note: The "Open input" will always open according to the settings of the dip switch panel (if the dip switch is set to Left Hand it will open left). The "Close input" will always open in the opposite direction of the "Open input" settings.

6.7 MAIN BOARD - CONNECTORS



6.8 TOP BOARD - CONNECTORS (MIRROR OF THE MAIN BOARD)

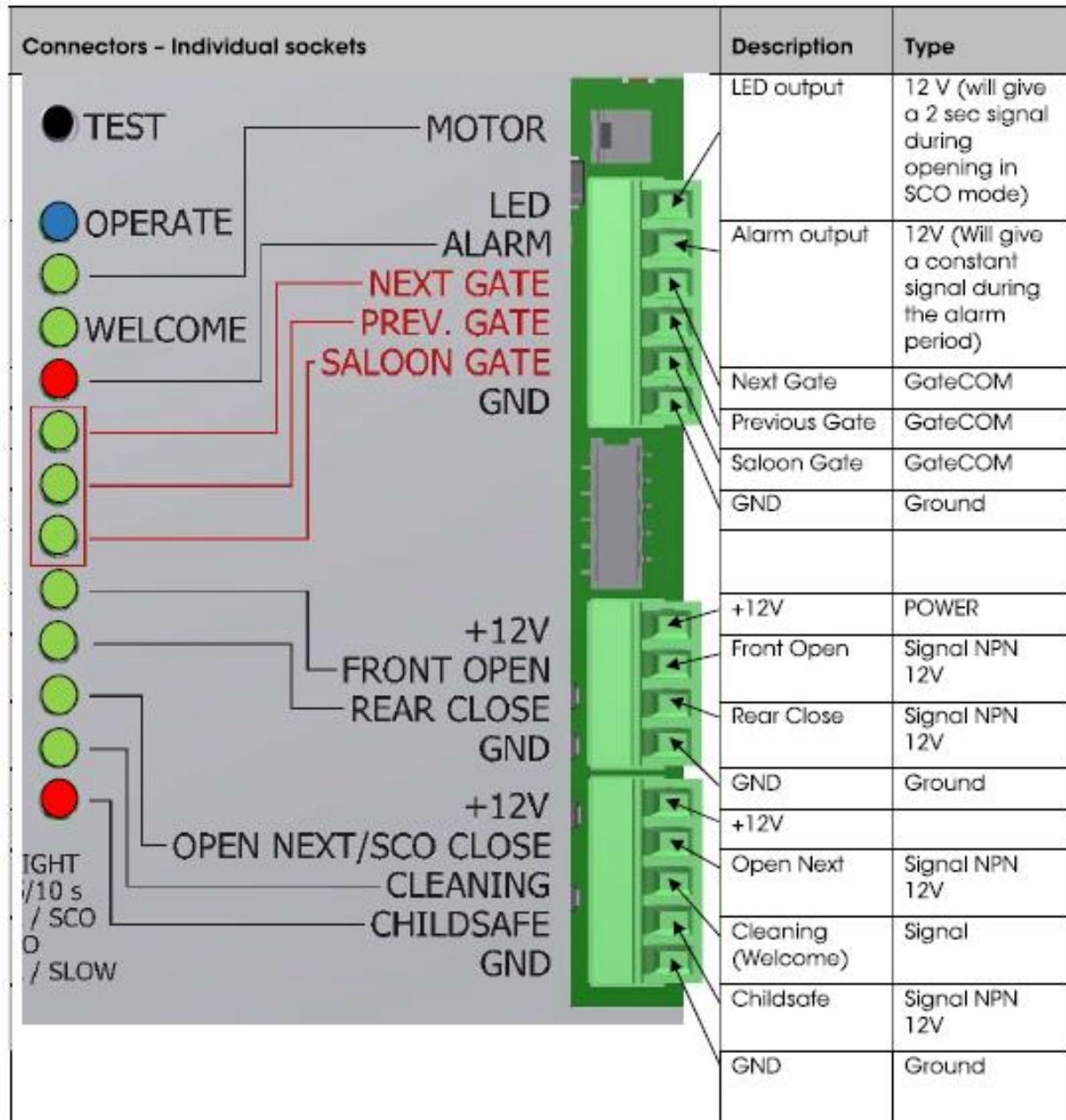


6.9 ADDITIONAL POWER SUPPLY IN AUTOGATE

To supply other units (i.g. ScanMaster Upright 2.0) with current an additional power supply can be installed at the Alphagate top board bracket. See how to install the additional power supply in the manual for ScanMaster Upright 2.0.



6.10 CONNECTORS - INDIVIDUAL SOCKETS



7 GateCOM

GateCOM is a serial data bus where communication is sent between (from different in & outgoing connectors) gates in a gate family. Some "messages" are sent to a specific gate (Previous Gate, Saloon Gate or Next Gate) and some "messages" are broadcasted to all members of the gate family.

GateCOM can be connected either at the Main board or at the Top Board, or as a mix of the two depending of the requirements of the installation.



NOTE: The GateCOM is a data bus and the use of a multimeter will not result in any interpretable information. One cannot measure the signal from a data bus.

To check the status of the GateCOM you only have to look at the LED light designated for each function:

- If both LED lights have a steady light = GateCOM OK.
- If any of the LED lights are flashing = GateCOM failure or wrong connection.

7.1 WIRING - GateCOM

To connect the GateCOM you only need a two core cable for GND and SIGNAL.

NOTE: Keep the GateCom cable separated from any high voltage power supply to avoid the risk for "over hearing" between the cables. Over hearing may cause the gates to fail in operation.

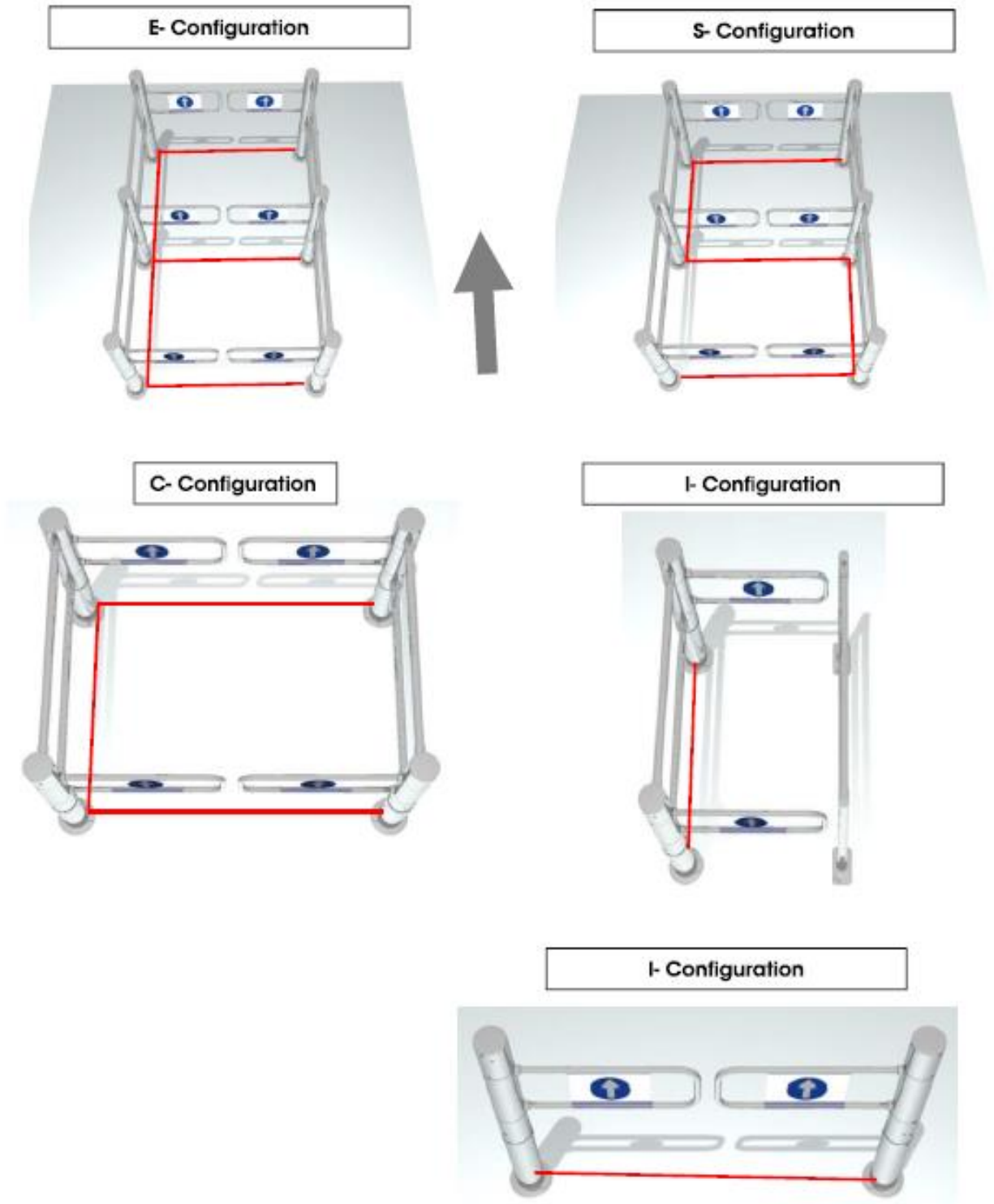
APPLICABLE CONFIGURATIONS

The only GateCOM configurations allowed are the ones where a "message" only can go ONE way between two gates in a gate family. If a "message" can go in two different ways from a gate there will be a conflict (see Unauthorized Configurations), concentricity, and the "message" will be sent to the next gate forever. This will cause the gate to "freeze", failure to function.

Authorized configurations are:

- E-configuration
- S-configuration
- C-configuration
- I-configuration

Red wire — = GateCOM



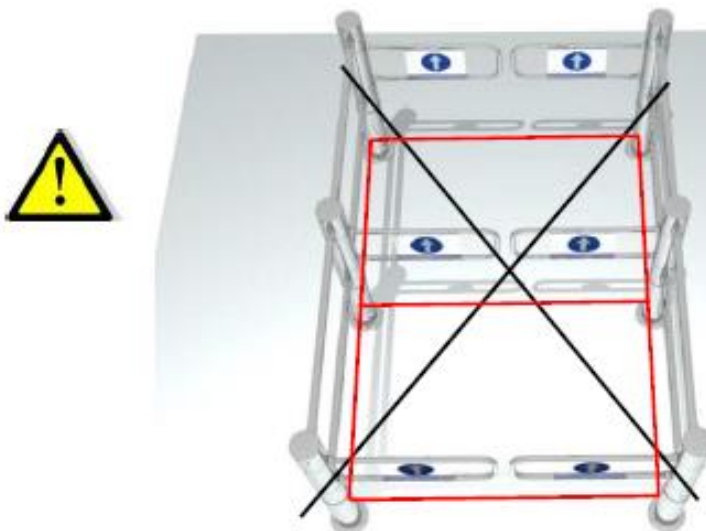
7.2 UNAUTHORIZED CONFIGURATIONS



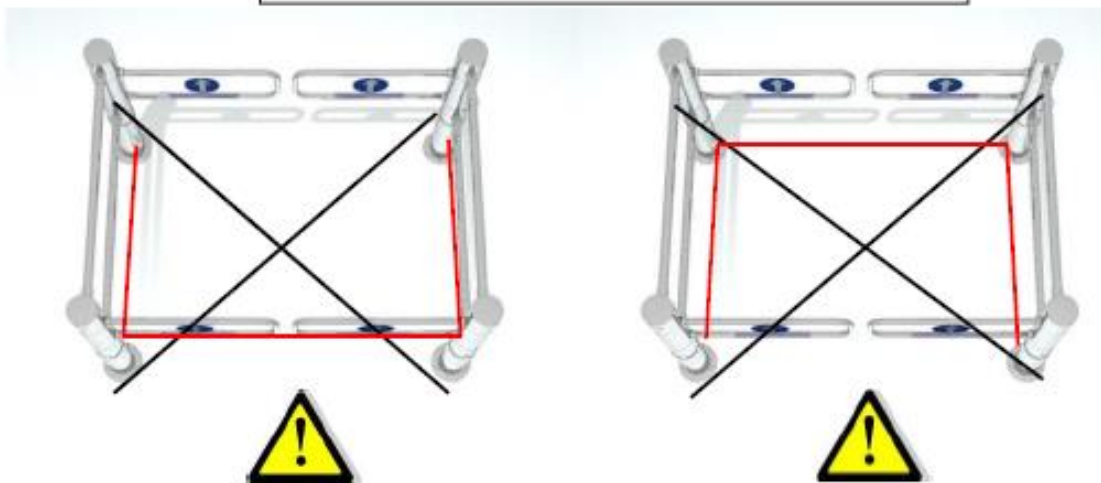
Configurations shown below are unauthorized. To wire a configuration according to the following examples will cause the gates to "freeze".

One cannot have double connections between the "lines" of gates (between 1st set of gates and 2nd and 3rd).

8- Configuration



U-Configuration (or upside down)



7.2.1 GATECOM – MASTER & SLAVE FUNCTION

For Alphagate models produced later than 2014-04-01 there is a Master & Slave function added. The purpose of the Master & Slave function is to make it easier to set the timer functions on the main board.

In a saloon configuration the right hand gate is ALWAYS the **Master**.

Instructions:

1. Set potentiometer number 1 and 3 on the **left** hand gate to maximum.

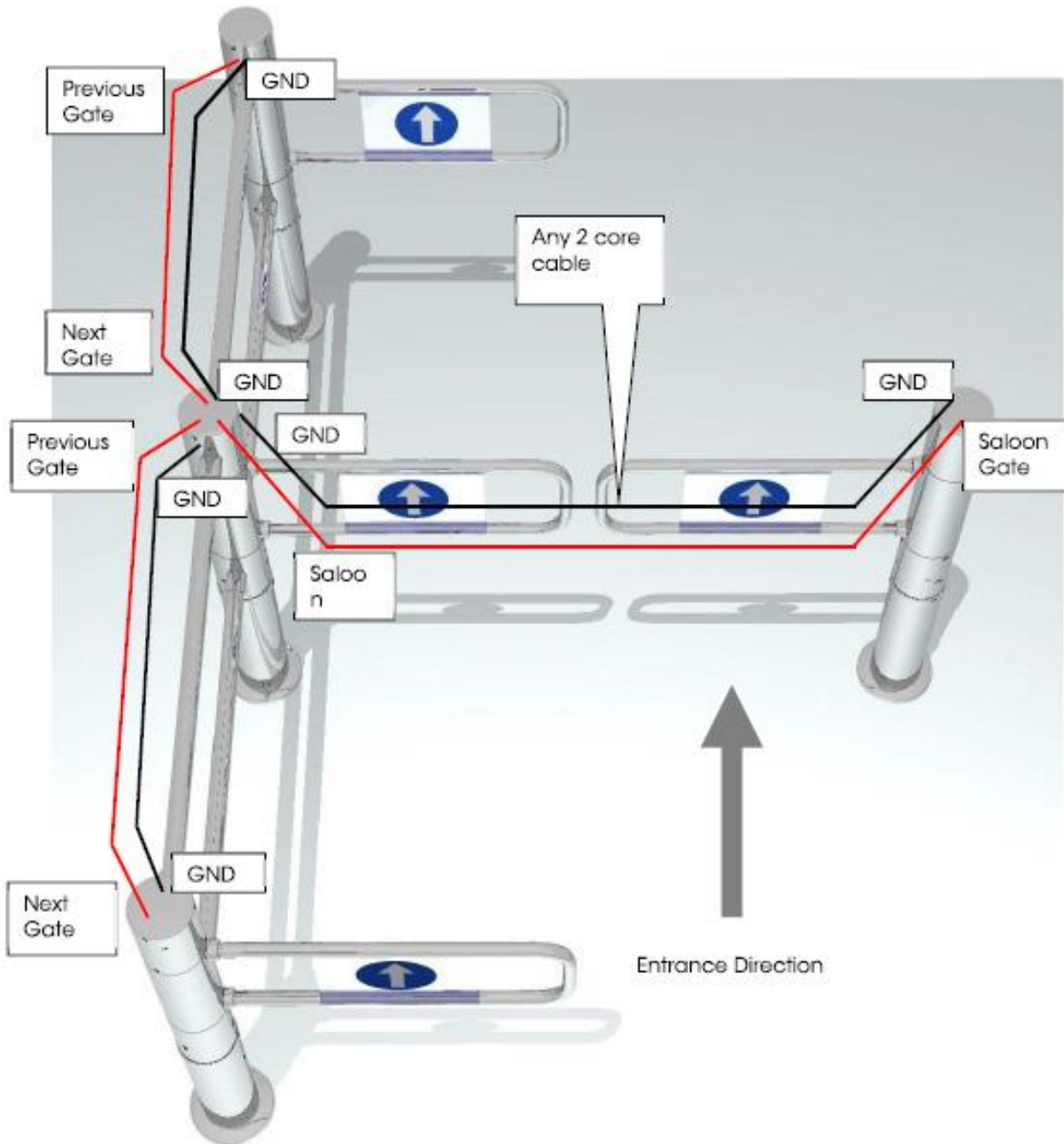


2. Then set the required time on the **right** hand gate and the left hand gate will follow the right hand gate.

NOTE: In order for the Master & Slave function to be operational the gate family (gate configuration) must be connected with GateCom (Saloon).

7.3 GATECOM - ORIENTATION

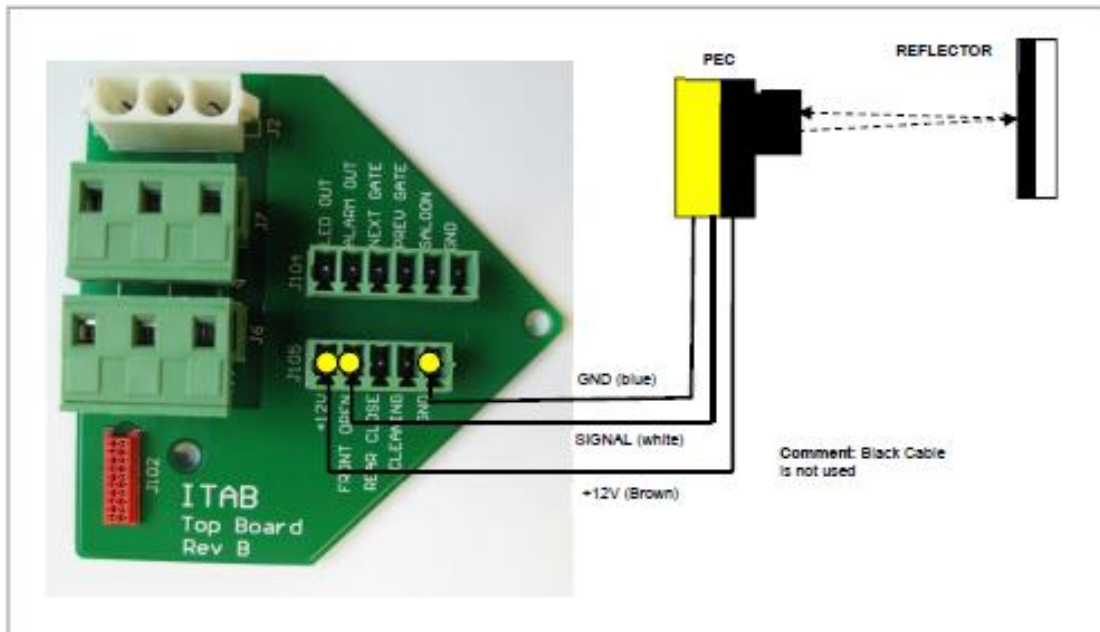
Below is an illustration of the orientation of the GateCOM bus from a gate.



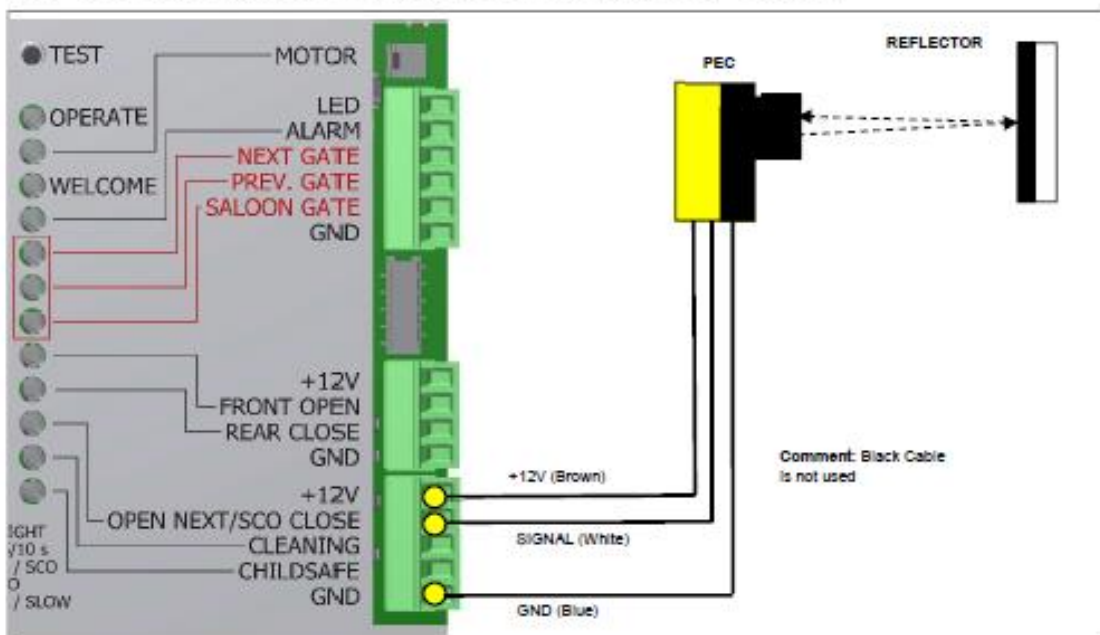
8 HOW TO CONNECT THE SENSORS?

The following examples explain how to connect the sensors to open the gate.

8.1 PEC UPRIGHT TO OPEN FIRST LINE OF GATES

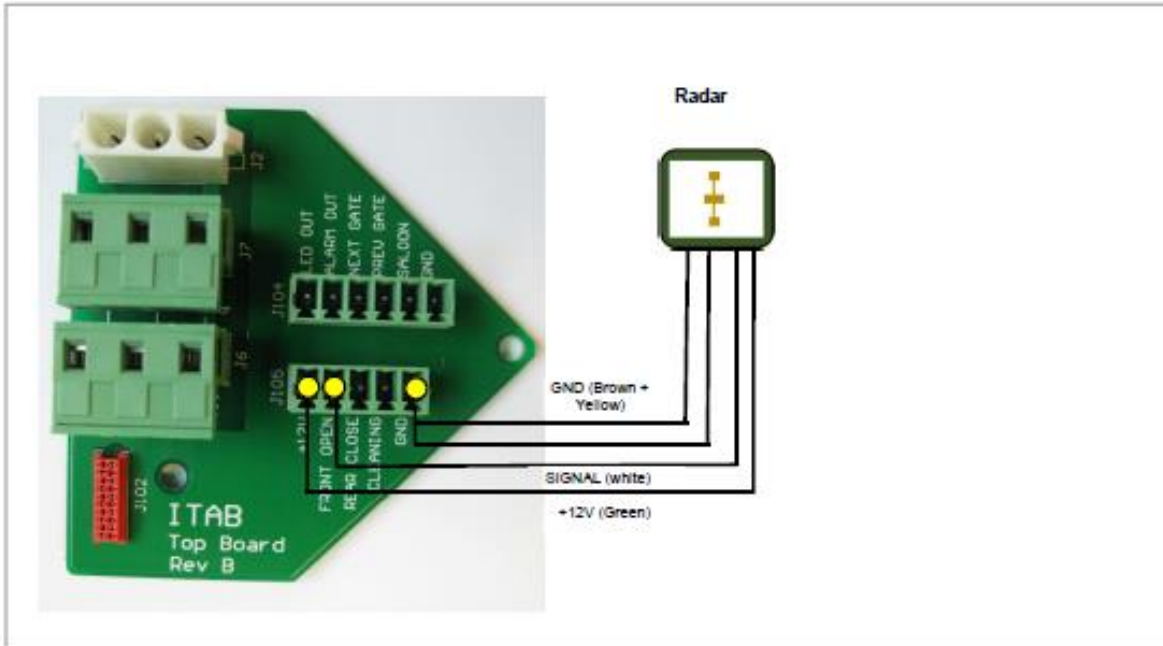


8.2 PEC IN GATE TO OPEN SECOND LINE OF GATES

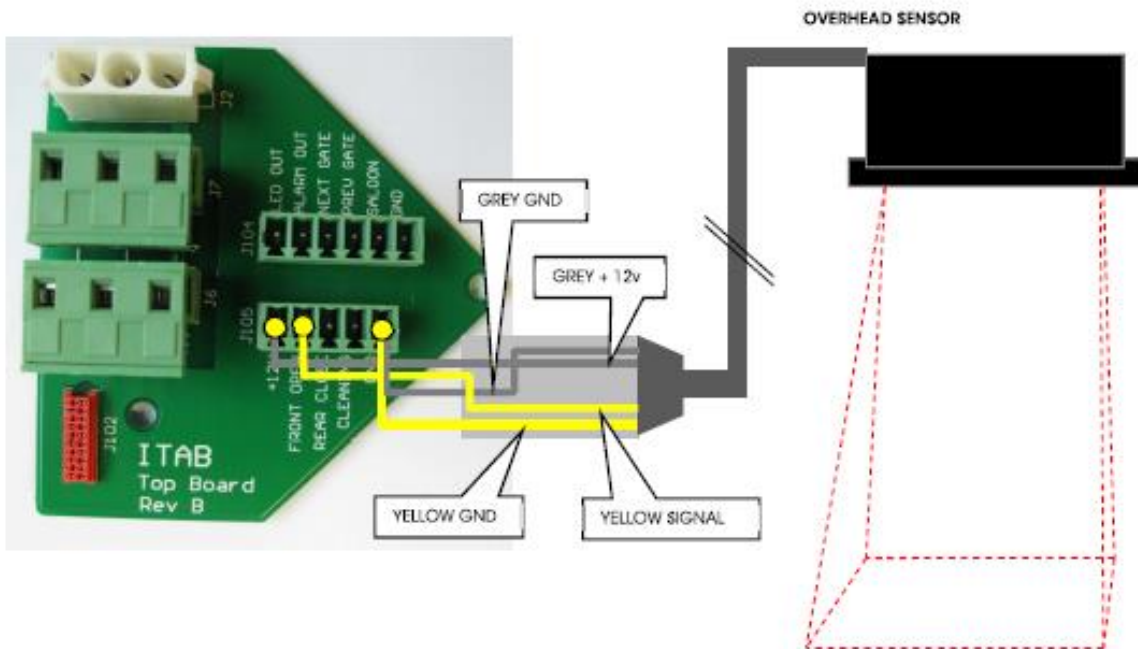


Note: when a local PEC is installed: the alarm will sound if the beam is broken when the gate is closes. "Shopping basket alarm"

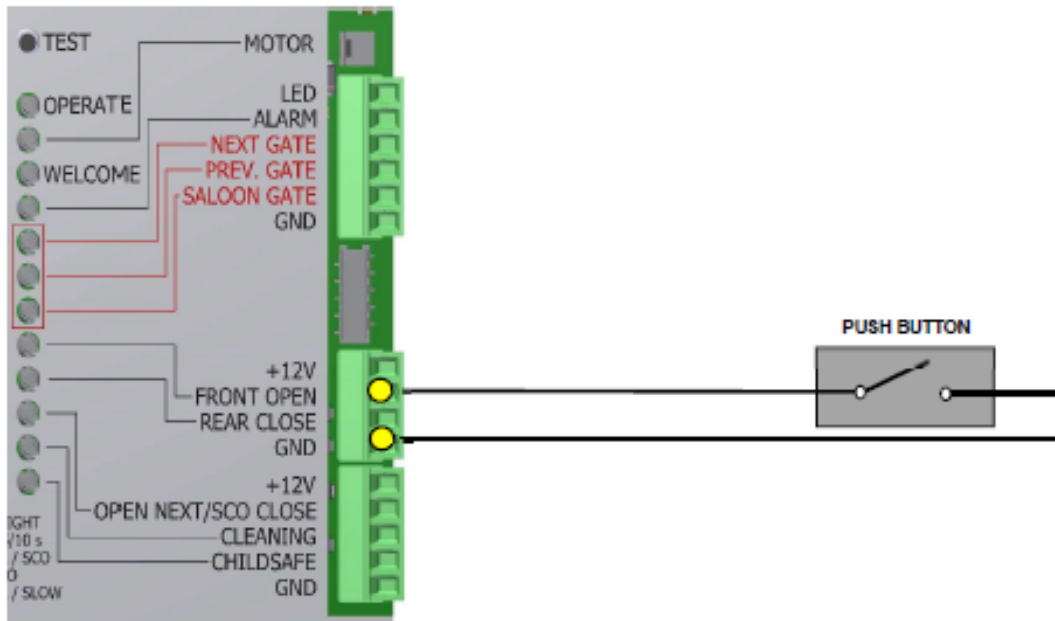
8.3 RADAR IN THE TOP OF THE GATE



8.4 OVERHEAD SENSOR



8.5 OPEN PUSH BUTTON



9 WHAT IS SECURE, WELCOME AND CLEANING MODE?

When installing a family of Alphagates, one can choose to accessorize the gates to achieve more functions than just a normal entrance gate.

Cleaning mode: When Cleaning mode is activated, the software is designed to keep the gates open in order to facilitate cleaning procedure of the surrounding area. Achieving the Cleaning mode requires a switch. *Note: Secure sensors will be ignored by the software when cleaning mode is activated.*

Cleaning mode activated = switch ON

(It is strongly recommended to use a switch when having Secure mode installed)

Secure mode: The Secure mode is designed to close the gates when someone tries to exit the wrong way. Achieving the Secure mode requires extra sensors.

Secure mode activated = always ON (when installed)

Welcome mode: The Welcome mode is designed to keep the gates open to achieve an open and yet secure entrance. To achieve Welcome mode one need to have secure sensors to make the gates close. It is recommended to use a switch to enable an "ON" and "OFF" function of the Welcome mode of the entrance system.

Welcome mode activated = switch ON

9.1 HOW TO CONNECT THE "CLEANING" / "WELCOME" BUTTON.

WELCOME can be connected as a remote installation or it can be connected by grounding "NEXT GATE" in the GateCom socket in the last line of the configuration.

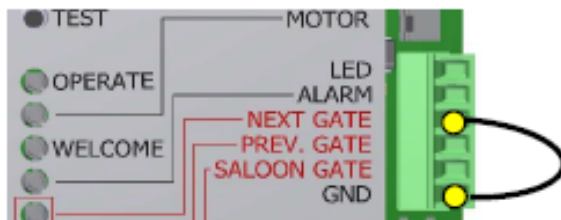
9.1.1 WELCOME AS A FIXED FUNCTION OF THE ENTRANCE SYSTEM

WELCOME mode requires the last line of gates to be equipped with Rear Facing Radars or an SDU (Single Directional Unit).

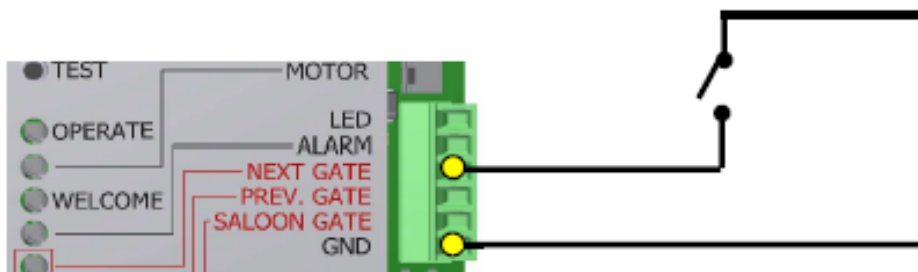
For the cleaning input there is a possibility to connect switches both for the CLEANING mode and for the WELCOME mode.

- The only thing needed to activate CLEANING mode is a standard switch to close the circuit (not springy).
- There are two options how to enable WELCOME mode. Connection is always made in a gate in the last line of gates where there is always a free connection (socket).

1. Jumper cable between GND and Next gate in Gate Com socket = gates are always open but will close on activation of wrong way sensor.



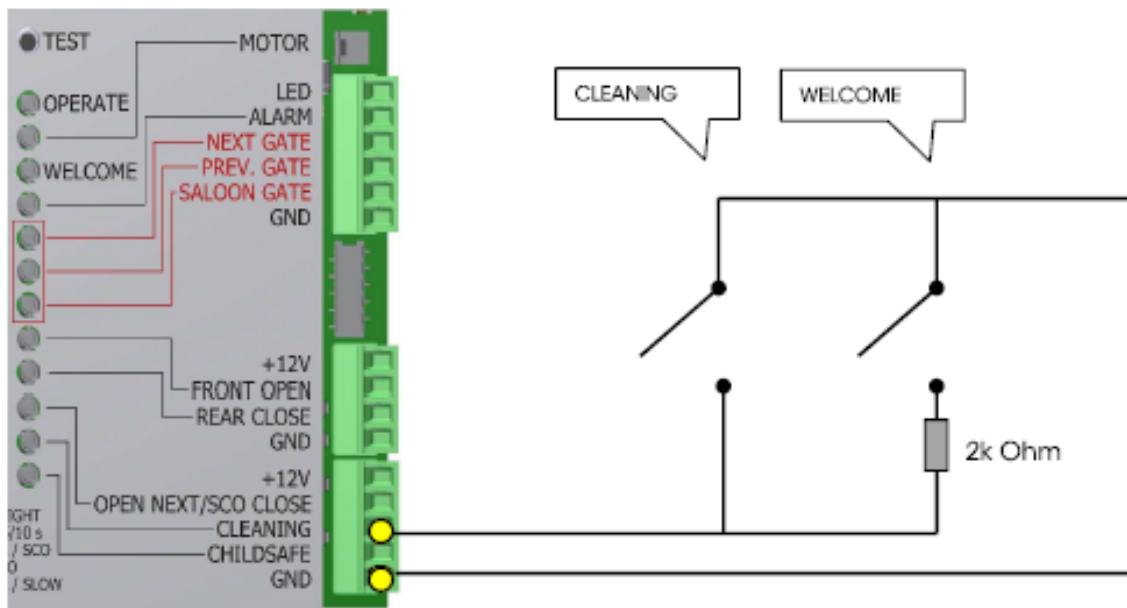
2. Switch connected between GND and Next gate in GateCom socket to have the options of both WELCOME mode (gates are always open but will close on activation of wrong way sensor) and SECURE mode (gates are normally closed and will close (forced closing = overriding opening signal) on activation of wrong way sensor).



9.1.2 REMOTE ON AND OFF FUNCTION OF WELCOME MODE

- To enable the WELCOME mode with one single cable for both Cleaning mode and a remote controlled fashion, a 2k Ohm resistance is needed along with the standard switch (not springy).

Remote CLEANING/WELCOME can be connected to ANY gate in a gate family.



9.2 CONNECTING EXTERNAL TRIGGERING (ACCESS CONTROLS)

Our standard format for connecting to an input is as follows....

To connect to our equipment, use a volt free normally open contact, closing on event of wanting the gate to open. Alternatively, an NPN open collector transistor output capable of switching a minimum of 50ma and with pulse width duration of minimum 100 milliseconds.

It is possible to connect external opening devices for the Alphagate, i.e. Fire alarm, Code lock, Key lock etc. Connection is made to "CLEANING" (CLEANING and GND).

Any triggering device with a 12 volts output will trigger the gate to open.

NPN = grounding signal. Grounding the signal between "signal" (Front Open) and "GND" will open the gate and keep the gate opened as long as the circuit is closed (grounded). Fire alarm is to be connected to CLEANING and GND because CLEANING has the highest priority.

10 WIRING OF LED CABLES IN AUTOGATE

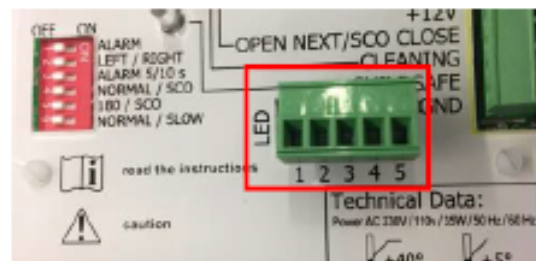
This gate has the LED drivers integrated on the main PCB. Wiring of the different functions are as follow.

Color of the LED light cable

Cable color	Function/LED Color
Black	12V
Green	Green
Red	Red
Blue	Blue

Normal Mode

Number on socket	Function
1	No Function
2	No Function
3	Alarm
4	Normal stage
5	12V



SCO Mode

Number on socket	Function
1	No Function
2	Closed position
3	Closing and Alarm
4	When opening
5	12V

If the same color wants on two functions, just add a cable between the two functions in the socket.

11 230V AC OR 110V AC GATE?

Standard configuration is 230V AC gate. To convert the gate to 110V AC the two bridges must be assembled according to picture below.



NOTE: The gate will be damaged if it has an 110V configuration and is connected to a 230V power supply.

12 FAQ

12.1 HOW TO TEST THE GATE?

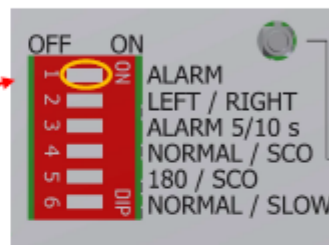
One can test the gate in two ways. Either by pressing the test button on the Main board or by short-circuiting between "OPEN" and "GND" on the Top Board or the Main Board.



NOTE: No adjustments for OPEN TIME, SECURE TIME, CHILDSAFE TIME will be considered by the main board when using the test button.

12.2 HOW TO TURN OFF THE ALARM?

The buzzer is switched on and off by DIP switch number 1.



12.3 HOW TO TURN OFF THE GATE?

The key switch will turn off the gate, but only the motor. When the key switch is turned off the blue LED light will flash. The main board is still powered up to supply power to possible sensors, in the turned off gate, for other gates in the gate family.

12.4 HOW TO CUT POWER SUPPLY TO THE GATE?

The power has to be disconnected from the mains terminal.



NOTE! Danger! The incoming power is high voltage (230V). This should only be done by a professional.

Note: This will disable the "Clean/Welcome" mode if it is connected to the gate where power is to be cut.

12.5 WHEN DO I USE NORMAL and SLOW?

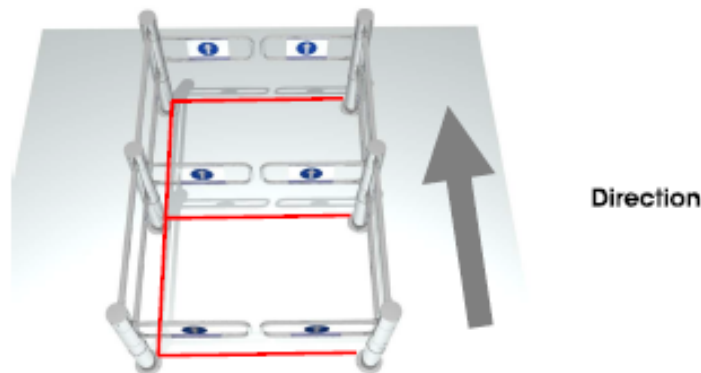
For all "normal" gate arms the dip switch setting should be "Normal" = standard speed. For deep gate arms, long glass arms (< 900 mm) or gate arms heavier than 3,5 kg the dip switch setting should be set to "Slow".

12.6 WHAT IS A GATE FAMILY?

A gate family is a set of gates where one has to pass through all the gates in the family to enter the premises/store.

Note: Two double saloons in parallel is not a gate family. You would either go through one of the saloons, not both. "Cleaning/Welcome" is connected by GateCOM and therefore all gates in a gate family communicate with each other. The GateCOM does NOT operate between two different gate families.

Example of a gate family



12.7 WHAT IS WELCOME MODE?

Instead of having the gates closed and then opened when a customer is entering the store one can choose to do the opposite by having them opened always and closing when someone tries to exit the wrong way. To make this feasible the last line of gates needs to be equipped with rear facing radars or an SDU (Single Directional Unit) to give a closing signal when someone tries to sneak out the back door.

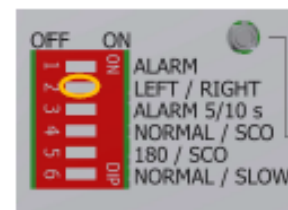
12.8 HOW TO TRIGGER THE ALARM (OUTPUT)

The gate will give an alarm if:

- The gate arm is pushed out of the rest position on the gate
- The gate arm is pushed out of the rest position of any gate in the gate family
- If the Close input gets a signal from any gate in the family.
- When the test button is pressed

12.9 HOW TO CHANGE SIDE OF THE GATE

To change side of the gate use DIP switch no. 2. (Left or Right). If the gate triggers with radar, the radar needs to be moved to be in the entrance direction. If Secure function is used with radar the radar needs to be correctly connected at the Top board after changing side of the gate.



13 TROUBLESHOOTING THE GATECOM

1. The GateCOM led light has three modes:
 - a. OFF (no light) = no connections (inputs) to the GateCOM are made.
 - b. ON (steady light) = connection is made and system is fully operational.
 - c. BLINKING light= connection is made but something is wrong with the GateCOM function.



If any led light for the three inputs for the GateCOM are flashing; Next, Prev. or Saloon, there is a malfunction in that GateCOM function. You can have all three connected but only one flashing light saying that there is a problem in that third connection, and the other two are OK.

Action: Make sure ALL connections of GateCOM are accurate. Only one signal connection in one GateCOM function is allowed, i.e. one connection to Saloon per gate (not one in the top board and then another in the bottom main board), and the same for Next and Prev.

If a connection is made, for instance, to the Saloon input and the led light for that input is flashing, there could be that there are two connections to that GateCOM function.

14 ACCESSORIES

- Threaded top clamp for top power feed
- Push Button for opening
- Push Button for cleaning mode
- Remote Control
- Single Directional Unit (SDU)
- Customer counter
- Childsafe sensor
- Additional power supply (for e.g. ScanMaster)

15 FAILSAFE OPERATION

- In the event of removing the mains power supply to the Alphagate, the gate arm is able to be manually pushed with a minimal force (less than 10 Nm) to open in both directions
- The gate arm will stay in any position it is moved to until power is restored
- On power being restored the gate arm will automatically reset to the pre-set normal position
- Gates are factory set to 55 - 60 Nm. (9.81 Newton's = 1Kg force!) and easily user adjustable

16 MAINTENANCE INSTRUCTIONS

The following inspection is recommended to perform on regular basis:

Mechanical Inspection		Interval
Structural Safety	Motorised column, photoelectric barrier and reflector column and all other columns	6 months
Rotation	Connecting tube between the columns	6 months
Mounting	Gate Arm	Monthly
Electrical Inspection		Interval
Earth conductor	Connecting contacts and connections	Checks when servicing the system
Photoelectric Barrier	Operation and Settings	Annually
Radar Detector	Operation and Settings	Annually
Motor	Functional check	Annually
Motor control	Functional check of cut out in event of over current (actuator blockage)	Annually
Signalling device (horn)	Panic alarm functional check	Annually
Key switch	Functional check	Annually
Limit switch	Functional check	Annually
Ultrasound sensor	Operation and Settings	6 months

17 CLEANING INSTRUCTIONS

CLEANING YOUR ALPHAGATE:

Use only a proprietary spray polish suitable for chrome, glass and plastic. A light buff should be sufficient to remove fingerprints and grease marks. Do not wash down with soap and too much water as it might compromise the functionality of the gate.